



Mianyang Weibo Electronic Co.,Ltd

Designing, Manufacturing and Supplying WB Series Electric Isolated

Transducer and Digital Electrical Transducer since 1989

USER MANUAL

WBI342U01-S DC current transducer

www.mywbdz.com

wbw@wbdz.cn

Tel: 86 0816 2971265

Fax: 86 0816 2281934

ISO9001 ISO14000 ISO18000

Certified

WBI342U01-S DC current transducer

Safety claim

The information in the safety claim of the equipment documentation is intended to ensure that equipment is properly installed in order to maintain it in a condition.

It is assumed that everyone who will be associated with the equipment will be familiar with the contents of that safety section, or this safety guide.

When electrical equipment is in operation, dangerous voltages will be present in certain parts of the equipment (e.g. the input terminal). Failure to observe warning notices, incorrect use, or improper use may endanger personnel and equipment and cause personal injury or physical damage.

Before working in the terminal strip area, the equipment must be isolated.

Proper and safe operation of the equipment depends on appropriate shipping and handling, proper storage, installation and commissioning, and on careful operation, maintenance and servicing.

The operating manual for the equipment gives instructions for its installation, commissioning, and operation. However, the manual cannot cover all conceivable circumstances or include detailed information on all topics. In the event of questions or specific problem, do not take any action without proper authorization. Contact the appropriate WB technical or sales office and request the necessary information.

Standard application

1. Accuracy

Accurate degree is conformed to IEC688:1992

2. Safety

2.1 Overload capability

Overload capability is conformed to IEC688:1992

2.2 Isolation voltage

Can be endured testing voltage is conformed to Q/72085584-0.1-2004

2.3 Insulation impedance

The insulation impedance is no less than 20M Ohm, is conformed to

Q/72085584-0.1-2004

3. Electromagnetic Capability

3.1 Electromagnetic field immunity test according to IEC 61000-4-3:1995

3.2 Power frequency magnetic field immunity test according to IEC 61000-4-8:1993

Product Description and Application

WBI342U01-S converts DC input current into a load independent output signal DC 0-5V, or 0-10V. It has adopted electromagnetic isolation principle for real time measurement of DC current from electric net or electric circuit.

The product has certain advantages of total galvanic isolation between input/output, high accuracy, low drifting by temperature, and wide temperature bearable range, etc.

Product Dimensional Drawing (unit: mm)

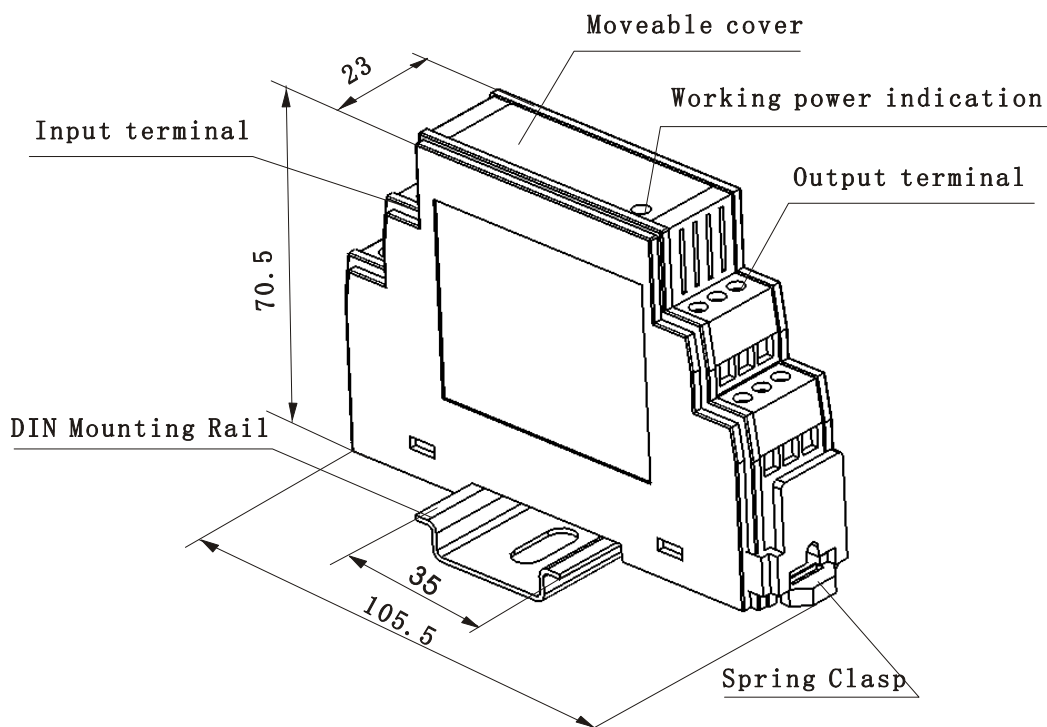

Product Terminal Identification Drawing

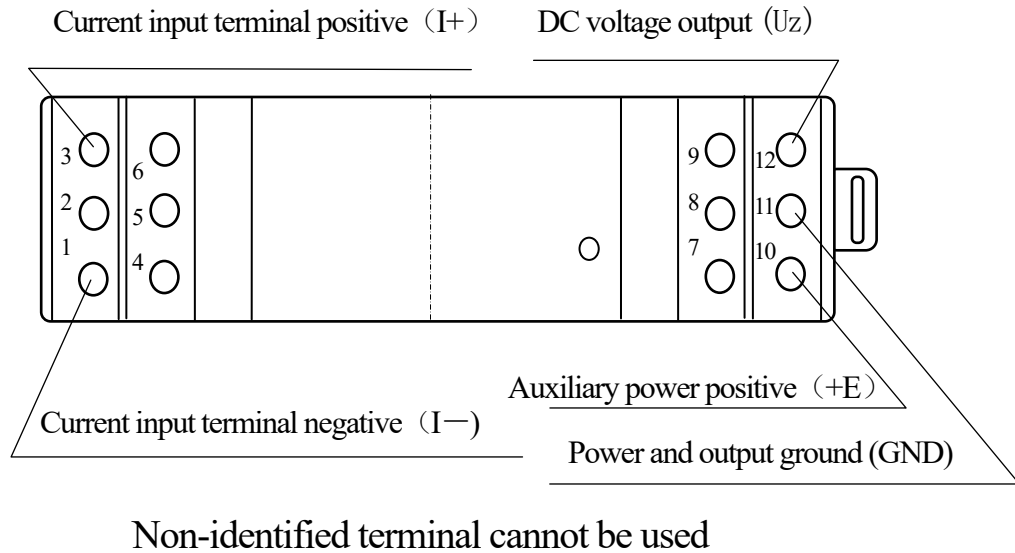

Key Technical Data:

1. Input: DC 0~1mA...0~5A;
2. Output: 0-5VDC; 0-10V DC;
3. Accuracy : 0.2%
4. Input Impedance (R): $R_i = 0.05V/I_x$ (I_x is the current be measured)
5. Linear Range: 0-120% of nominal input
6. Responding Time: 150ms
7. Over Load Capacity: 10 times of nominal input, for 5 seconds;
8. Maximum Load (Output current) : 5mA
9. static current: 10mA
10. Auxiliary Power: +12Vdc +24Vdc
11. Isolation Voltage: 2500Vdc, for 1 minute
12. Output Ripple: <10mA
14. Drifting by Temperature: $100 \times 10^{-6}/^{\circ}\text{C}$
15. Ambient Temperature: $-10^{\circ}\text{C} \sim +50^{\circ}\text{C}$

16. Mounting : DIN Rail 35mm Mounting

Instruction of Installation and Use

1. The product has adopted structure compliance with EN50022; suitable for DIN rail mounting NS35/7.5, NS35/15. Installation steps are as following (please reference to dimensional drawing):

Step 1: Immobilize one side of product's mounting trough to the DIN mounting rail;

Step 2: Pull out the spring clasp;

Step 3: Place whole mounting trough to the DIN mounting rail properly;

Step 4: Release spring clasp to make sure the installation.

2. The product has calibrated before out of factory. After correctly wiring, it can be powered and used immediately. But for further precise signal sampling, user needs to warm-up the product for 3 minutes before use.
3. The auxiliary power requires isolation voltage $\geq 2000\text{VAC}$, DC current output ripple $< 10\text{mV}$.
4. Multiple transducers can share with one set auxiliary power together., and the wire shared between the transducers and power should be short. It's better to connect each transducer to the auxiliary power individually.
5. Wiring in terms of the terminal identification drawing strictly.
6. Basic testing method for accuracy

(1) According to the terminal definition table to connect the testing circuit;

(2) The testing must to be done by under the following conditions;

Auxiliary power: $24\text{V} \pm 5\%$, ripple $\leq 5\text{mV}$

Ambient temperature: $25^\circ\text{C} \pm 5^\circ\text{C}$

Relative humidity: RH(45~75)%

Accuracy for Signal Power Source instrument: 0.05

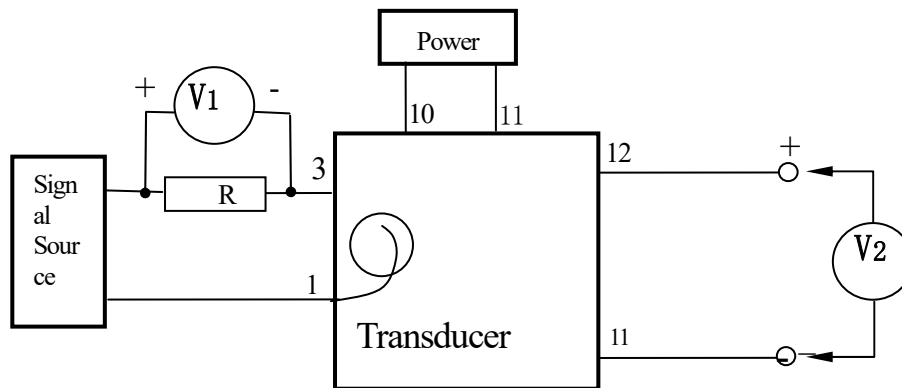

- (3) Warming up the transducer for 3 minutes
- (4) using output monitoring meter V1 to measuring the output of signal power source instrument, set a any input value which is within the measuring range of the transducer I_r (e.g. if input value is 5A, the output is 0-5V, the expected output value U_z should be calculated as:

$$U_z = 5V \times I_r / 5A$$

- (5) Using output monitoring meter V2 to measuring the output voltage U_o of the transducer, the basic introduced error γ of the transducer should be calculated as:

$$\gamma = (U_o - U_z) / 5V \times 100$$

- (6) Repeating step (4) (5), if calculated absolute value is less than the given accuracy value of the transducer, it shows the transducer's accurate grade is qualified.

Caution:

1. Pay attention to the auxiliary power information, especially the auxiliary power grade, and polarity, other wise will damage the product.
2. pay attention to the wire connection; wrong terminal connection will cause

- malfunction of the product and even damage the product;
3. Don't dismantle the product, and carry with care to avoiding bump and fall of the product;
 4. If the product has been using under the environment with strong magnetic field interference, please pay attention to the shield of input wire, and the output signal wire should be as short as possible. For product intensive installation, the space between each product should not be smaller than 10mm.
 5. Only use identified terminals.
 6. There is no lightning strike prevention circuit design in this product. For out door and hazardous environment using, please add protective alternatives.
 7. This product uses fire prevent ABS crust, its temperature withstand is only limited as +85°C, higher than this limitation will cause the product deformation. Please use and store carefully.